

(No Model.)

H. AYRES.

2 Sheets—Sheet 1.

SCAFFOLD.

No. 405,195.

Patented June 11, 1889.

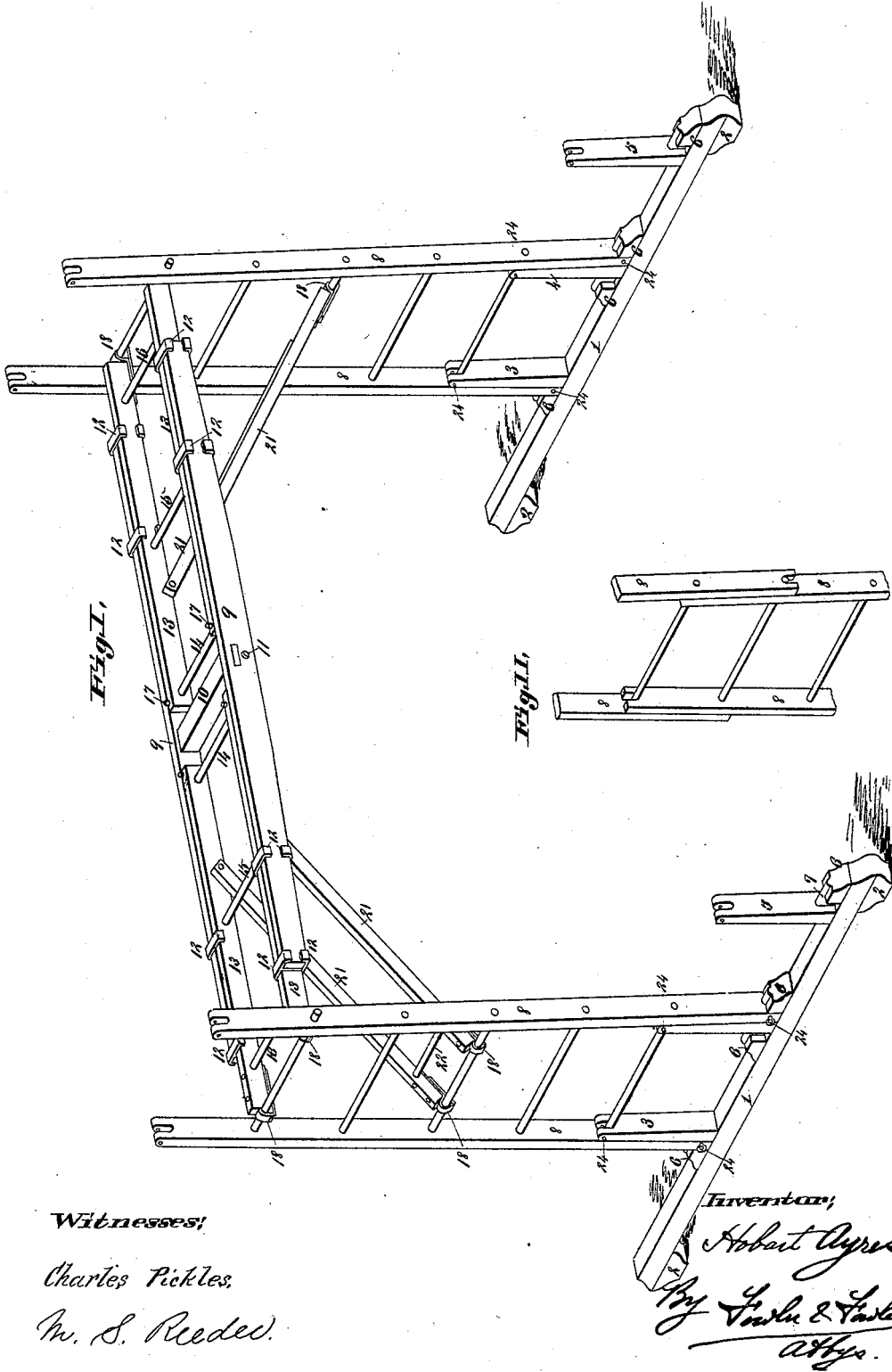

Witnesses:

Charles Pickles.

M. S. Reedes.

Inventor,

Hubert Ayres

By Charles & Taylor
Attys.

(No Model.)

H. AYRES.
SCAFFOLD.

2 Sheets—Sheet 2.

No. 405,195.

Patented June 11, 1889.

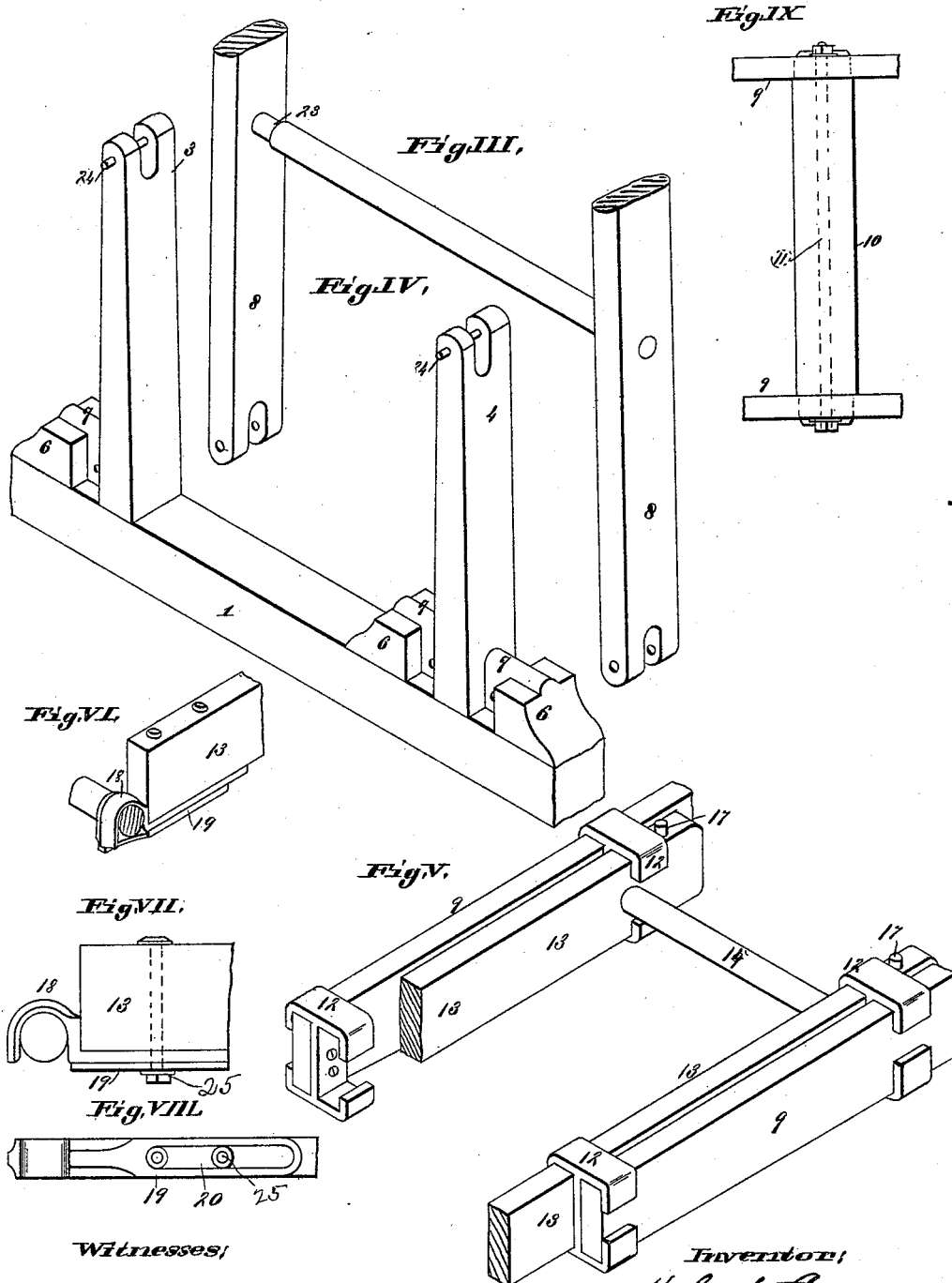

Witnesses;

Charles Pickles,
M. S. Reeder.

Inventor;

Hobart Ayres
By Forster & Forster
Attys.

UNITED STATES PATENT OFFICE.

HOBART AYRES, OF ST. LOUIS, MISSOURI, ASSIGNOR TO PETER BENT, OF CHICAGO, ILLINOIS.

SCAFFOLD.

SPECIFICATION forming part of Letters Patent No. 405,195, dated June 11, 1889.

Application filed July 23, 1888. Serial No. 280,754. (No model.)

To all whom it may concern:

Be it known that I, HOBART AYRES, a citizen of the United States, residing at St. Louis, in the State of Missouri, have invented certain
5 new and useful Improvements in Scaffolds, of which the following is such a full, clear, and exact description as will enable any one skilled in the art to which it appertains to make and use the same, reference being had to the ac-
10 companying drawings, forming part of this specification.

My invention relates more particularly to extensible ladders and scaffolds.

The object is to construct a cheap, light,
15 durable, and strong scaffolding made of ladders—one that may be made of any height and that can be extended in length.

The invention consists, briefly, in a ladder-base to which a ladder can be secured vertically in one or more positions, said ladder being
20 connected by a platform, which is preferably extensible, to another ladder arranged in the same manner.

The invention consists, also, in details of
25 construction, which will now be described in full, and the novel features thereof particularly pointed out in the claims making a part hereof.

Figure I is a perspective of a ladder-scaffolding embodying my invention. Fig. II is a perspective showing how two ladders may be joined so as to make the scaffolding higher. Fig. III is a perspective, on an enlarged scale,
30 of the lower part of one of the ladders. Fig. IV is a perspective of a part of the ladder-base, on an enlarged scale. Fig. V is a perspective, also on an enlarged scale, of a part of the extensible platform or section between the ladders. Fig. VI is a detail showing how
40 the platform is secured to the ladders. Fig. VII is a side view of Fig. VI. Fig. VIII is a bottom plan view of the hook which fastens the platform to the ladders, and Fig. IX shows how the fixed section of the movable platform
45 is joined together.

The same figures of reference indicate the same parts throughout the several views.

1 is the ladder-base, which may be provided with feet 2 2. From this base extend uprights
50 3, 4, and 5. These uprights are provided with

notches in their upper ends, which embrace the rungs of the ladder when placed upon the base.

6 are blocks which are fastened to the ladder-base and abut against the uprights. These
55 blocks are made with a central portion 7, leaving two cut-away places on each side of the same. The central portion 7 abuts against the uprights, as clearly shown in Fig. IV. The central upright 4 has a block 6 abutting on
60 each side thereof, while the uprights 3 and 5 have blocks 6 abutting against the outer side thereof.

8 are the ladders, which are provided with notches at each end. These ladders are made
65 tapering—that is to say, wider at the bottom than at the top—and are made so that the top rung projects at each side of the side rails. The object of this is to allow two ladders to be secured together, as shown in Fig. II,
70 wherein the notches in the lower part of the second ladder take against the extension of the rounds of the first ladder, and the last round of the second ladder takes in the notches in the upper part of the first ladder. 75

Between the two ladders is arranged, preferably, an extensible platform composed of a fixed section 9, fastened together by a cross-piece 10, through which a bolt 11 preferably
80 passes. This cross-piece 10 and bolt are the only means by which the two parts of the fixed section 9 are joined together. To the fixed section 9 are attached double T-irons 12, two at each end, upon each of the two parts of said fixed section. The parts of the
85 T-irons that project toward the center of the platform form ways on each side of the two parts of the fixed section (see Fig. V) in which the movable sections 13 slide. The two parts of the movable section 13 are joined together
90 by rods 14 15 16. The movable sections 13 are provided with pins at their inner ends, which are adapted to strike against the T-irons and limit the outward movement of said movable sections. Each rail of the movable section
95 is provided with a hook 18, which is adapted to embrace the rounds of the ladders, as clearly shown in Figs. VI and VII. Two bolts secure the hooks 18 to the rails of the movable section, and also secure in place a slid- 100

ing piece 19, which locks the hooks of the movable section to the rungs of the ladder when the slide is moved forward, as shown in Fig. VI. By moving the slide 19 backward the hooks can be freed from the rungs. The slide 19 is provided with an elongated slot, which embraces an elongated lug 20, that extends from the plates by which the hooks are secured in position. Bolts 25 pass through the elongated lug, as clearly shown in Fig. VIII. The nut and washer on the end of the bolts 25, as shown in Fig. VII, hold the slide 19 in place. From each of the rails of the movable sections 13 extends a strut 21, which is pivoted to said rails. The struts 21 of each movable section are connected together by a rod 22. The struts at their lower ends are provided with hooks 18 of the same construction as previously described, and are adapted to fasten and hold the platform securely to the ladders. The lower rungs of the ladders adjacent to the side rails are notched, as shown by 23 in Fig. III. This notch allows the ladders to be fastened together more securely. This feature, together with the tapering ladders, the projecting rung at the top of the ladder, and the notches in the ends of the side rails of the ladder, forms no part of the present invention, the same being covered by me in Letters Patent No. 311,406, granted on the 27th day of January, 1885.

24 are pins that may be inserted through holes provided in the uprights, the ladder-rails, and in the cut-away portion of the block 7, to secure the ladders to the uprights more securely, if desired. These can be dispensed with in most cases. By joining two or more ladders, as shown in Fig. II, the platform can be made of any height, and by drawing the movable sections outward the platform can be extended to any desired length.

The scaffolding described can be used for almost any purpose. When in the position shown, it can be used for overhead work; but when it is necessary to get near a wall or some object at the side the ladders are removed from the uprights 3 and 4 and secured between the uprights 4 5. When it is desired to work on a wall or object at the other side, the scaffolding can be turned end for end when the ladders are placed between the uprights 4 5. This will bring the scaffolding near to the side of the wall upon the other side.

The ladders of the scaffolding afford ready means for getting up to the platform, and for this reason are preferable to other kinds of scaffolding. They are also preferable for the reason that the hooks can be secured to any of the rungs of the ladders and the platform adjusted to almost any height. So, too, by placing two or more ladders together the platform can be used for great heights. The arrangement is a strong and simple one, the struts 21 acting to make the structure a truss. A non-extensible platform could be used with

the ladders to make a scaffolding, in place of an extensible platform, if desired. The piece 1 is made of considerable length, so as to make a broad base and add greater stability to the scaffolding.

It is obvious that various changes may be made in the details of my invention without departing from the spirit thereof. I do not wish, therefore, to limit myself to the exact arrangement and devices described.

What I desire to claim and secure by Letters Patent of the United States as my invention is—

1. A ladder-base consisting of a timber, as 1, having notched uprights extending therefrom, and a ladder resting upon said timber, the rung of which is adapted to engage the notches in the uprights.

2. A ladder-base consisting of a timber, as 1, having notched uprights, as 3, 4, and 5, extending therefrom along its length, and a ladder resting upon said timber, the rung of which is adapted to engage the notches in two of the adjacent uprights.

3. The combination of a timber 1, notched uprights 3 4 5, extending therefrom, and blocks 6, having central portions 7 abutting against said uprights in the manner described, and a ladder having the ends of the side rails notched.

4. The combination, to form a scaffolding, of two timbers, as 1 1, notched uprights 3, 4, and 5, extending from each of said timbers, ladders resting upon said timbers, the rungs of which engage the notches in two adjacent uprights on each timber, and a platform between said ladders.

5. The combination, to form a scaffolding, of ladder-bases, as 1 1, each having notched uprights 3, 4, and 5 extending therefrom, ladders resting upon said bases, the rungs of which engage the notches in two adjacent uprights on each ladder-base, and an extensible platform between said ladders, for the purpose described.

6. A ladder-base consisting of a timber, as 1, uprights extending therefrom, and blocks 6, having central portions 7 abutting against said uprights in the manner described, and a ladder having the ends of its side rails notched and adapted to engage the central portions 7 of the blocks 6, as described.

7. The combination of a ladder-base, as 1, the uprights 3 4 5, extending therefrom, having blocks 6, with cut-away portions 7 abutting against said uprights, a ladder having notches in its side rails adapted to engage the uprights 3 4 or 4 5, as the case may be, and an extensible platform adjustably secured to said ladder and to a similar structure at the other side thereof.

8. An extensible platform for ladder-scaffolding, consisting of a fixed section 9, joined together by cross-piece 10, a sliding section at each side of said cross-piece 10, struts extending from said movable sections, and hooks se-

cured to each of said struts and to each rail of the movable sections, adapted to engage the rungs of ladders at each side thereof.

5 9. The combination, as hereinbefore described, to form a ladder-scaffolding, of a base 1, having uprights 3, 4, and 5 notched at their upper ends, blocks 6, having cut-away portions 7 abutting against said uprights and arranged in the manner described, a ladder 8, 10 having notches and adapted to be secured to said uprights, as described, a similar structure arranged at some distance therefrom, and an extensible platform between the two, consisting of a fixed section 9, having therein two 15 sliding sections 13, adapted to be hooked to the rungs of said ladders, and struts 21, pivoted to said sliding sections, and also adapted to be hooked to the rungs of said ladders, in the manner described.

20 10. The combination, with a ladder-support, of an extensible platform consisting of a fixed section 9, two or more double T-irons secured to said fixed section in the manner described, two sliding sections, the rails of which are 25 embraced by said T-irons, struts pivoted to the rails of said movable section, and hooks secured to the rails of said sliding sections, adapted to embrace the rungs of the ladder, and a slide or lock to secure said hooks to the 30 rungs of said ladders, as and for the purpose described.

11. The combination of the ladder-base 1, notched uprights 3 4 5, extending therefrom, blocks 6, having cut-away portions 7 abutting against said uprights and arranged in the 35 manner described, a ladder 8, having notches and secured to said uprights, as set forth, a similar structure suitably arranged with reference to the former, and an adjustable platform between the two, consisting of the fixed 40 section 9, joined together by the cross-piece 10, the double T-irons 12 12, fastened to the rails of said fixed section, sections 13, sliding in said double T-irons in the manner described, 45 struts 21, pivoted to the rails of said movable sections, and hooks 18, secured to the rails of said movable sections and to the struts, adapted to embrace the rungs of the ladders and having a slide 19, for locking said hooks to the ladders, substantially as and for the 50 purpose described.

In testimony whereof I have hereunto set my hand and affixed my seal, this 13th day of July, 1888, in the presence of the two subscribing witnesses.

HOBART AYRES. [L. S.]

Witnesses:

A. C. FOWLER,
THOMAS M. GRACE.